

C  
10.5"  
267



**Hannay Reels®**  
*The reel leader.*

# Audio/Video Reels

Production and Recording Facilities	Television and Radio Stations		
Live Events and Concerts	Mobile Broadcast Units	Satellite and Cable Companies	
Fiber Optics	Military	Mining	Communications



**You Can't Buy  
A Better Reel.**

Family owned and operated since 1933

# CONTENTS

Hannay cable reels come in all sizes and capacities.

Reel Type	Page
Series AVF	3
Series AV	4
Series AVD	5
Series AVC	6-7
Series AVC 1500	8
Model AVX-100	9
Series AVC1150/AVACT1250	10
Series AVCQ20-14-16	11



### Stay connected on the move.

From underground mining to on-the-scene news reporting to military operations, we offer portable and stationary electric cable reels to meet all your communication needs. We have thousands of standard reels – or can create custom designs – that are built strong to last long, require minimal maintenance, and provide a lifetime of value.

Our portable reels allow for easy setup and tear down with an ergonomic handle design, while our storage reels are stackable for easy transport. All of our AV and AVX reels meet international standards and are designed and constructed specifically for your business – never retrofitted to the job – so you can expect unsurpassed fit and function.

#### Designed for:

- Production and recording facilities
- Live events and concerts
- Mobile broadcast units
- Satellite and cable companies
- Mining operations
- Military communications
- Pipeline inspection

#### Uses:

- Video inspection
- Audio / Video / Broadcast
- Live electric cable
- Fiber optic cable
- Cable storage



# Series AVF

**For use with 3mm to 9.2mm or larger broadcast fiber optic cable.**

- Designed for Tactical Fiber and Hybrid Fiber cable types.
- Quality construction designed for harsh outdoor environments.
- Non-reflective black matte finish is standard.
- External and/or internal drum storage with protective rubber grommet for easy access to lead out cable, while keeping dirt and debris out.
- Crank handle permanently attached to disc.
- Equipped with cam-lock drag brake system

**AVF-14**

- Lightweight aluminum construction, under 10 lbs., for easy transport and handling.
- Modular frame style, handle and legs can be replaced in the event of damage.

**AVF-18**

- Durable aluminum/steel construction, under 25 lbs.
- Holds 1000 feet of SMPTE Cable.
- Frame style with clips allow multiple reels to be stacked.
- Optional heavy-duty, locking caster wheels (set includes 2 locking and 2 non-locking casters). Specify when ordering, add "C" to model number.
- Optional pull handle is available (Part No. 9949.0500). Specify when ordering.

**AVF-14**

Standard configuration shown



**AVF-18C**

Standard configuration shown with optional casters. Inset: AVF-18 Shown stackable with pull handle



**AVF Series includes two durable rubber twist ties for cable ends.**

Part No. 9949.0082

**PARTS DRAWING – AVF-14–ISO 261, AVF-18–ISO 262**

Model Number	Cable Capacity of Reel feet m							Approx. Weight without cable lb. kg		Reel Dimensions in. mm							
	Type O.D. (mm)	TAC 1 4.5	TAC 2 5	TAC 4 5.5	TAC 6 6	TAC 12 7	SMPTE 311M 9.2	NET	UPS/ FedEx. SHIP Wt.	A	B	C	D	E	F	G	H
<b>AVF-14</b>	<b>1500</b>	<b>1300</b>	<b>1000</b>	<b>800</b>	<b>600</b>	<b>350</b>	<b>9.5</b>	<b>58*</b>	<b>9.50</b>	<b>6</b>	<b>6</b>	<b>13.5</b>	<b>14</b>	<b>13.25</b>	<b>18.25</b>	<b>7.94</b>	
	457	396	305	244	183	107	4.3	26	241	152	152	343	356	337	464	202	
<b>AVF-18</b>	<b>4000</b>	<b>3000</b>	<b>2500</b>	<b>2000</b>	<b>1600</b>	<b>1000</b>	<b>24</b>	<b>80*</b>	<b>13</b>	<b>9</b>	<b>8</b>	<b>20</b>	<b>18.5</b>	<b>16.25</b>	<b>20.5**</b>	<b>10</b>	
	1219	914	762	610	488	305	11	36	330	229	203	508	470	413	521	254	

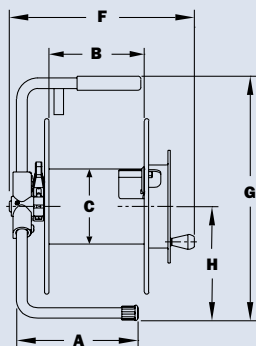

AVF-14

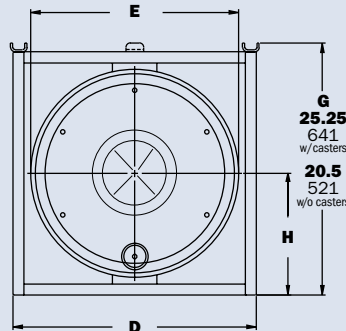
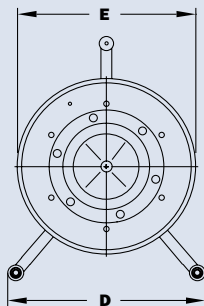

AVF-18

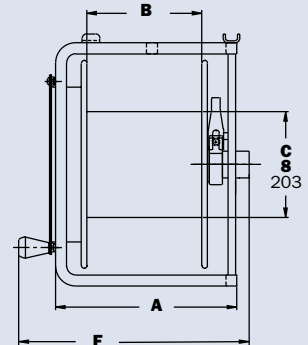

**Notes:**

1. Specifications subject to change.
2. Be sure to check dimensions and weights prior to ordering.

\*Dimensional weight applies when shipped as a parcel package (via FedEx or UPS Ground).

\*\*For Model AVF-18 casters will add 4-3/4" to "G" dimension. When ordering casters add "C" to model number: AVF-18C.



# Series AV

**For fast rollout and storage.**

- Broadcast and pro-audio applications. The reels are stackable and have side-mounted connector panels.
- Rugged steel and aluminum construction throughout. Square tubing frame.
- Black, non-reflective matte finish.
- Equipped with one durable rubber twist tie for cable ends.
- Removable side panel (blank panel is supplied as standard).
- Standard strain relief inside panel compartment.
- Frame clips allow stacking.
- Optional heavy-duty, locking caster wheels (set includes 2 locking and 2 non-locking casters).
- Optional pull handle is available for AV-2 and AV-3 (Part No. 9949.0500). See page 5.
- Adjustable cam-lock drag brake.



**AV-1**  
Standard with caster mounting plates



**AV-2**  
Shown with optional casters (cable and punched end plate not included)



**AV Series includes one durable rubber twist tie for cable ends.**  
Part No. 9949.0082

**PARTS DRAWING – AV-1-ISO 190, AV-2-ISO 191, AV-3-ISO 231**

Model Number	Cable Capacity of Reel feet m									Approx. Weight without cable lb. kg			Reel Dimensions in. mm							
	O.D. (in) O.D. (mm)	.25 6	.32 8	.38 10	.41 10	.45 11	.49 12	.58 15	.67 17	NET	UPS/ FedEx, SHIP Wt.	Freight SHIP Wt.	A	B	C	D	E	F	G	H
AV-1	600	350	225	200	150	125	-	-	-	14	58*	21	10.5	7	6	13.75	11.75	14.25	14.25	7
	183	107	69	61	46	38	-	-	6	26	10	267	178	152	349	298	362	362	178	
AV-2	-	-	-	750	600	500	350	250	-	25	80*	30	13	9	8	20	18	16.25	20.5	10
	-	-	-	229	183	152	107	76	11	36	14	330	229	203	508	457	413	521	254	

**Notes:**

1. Specifications subject to change.
  2. **Be sure to check dimensions and weights prior to ordering.**
  3. Casters will add 2-3/4" to "G" dimension on AV-1 and AV-3.  
Casters will add 3-1/2" to "G" dimension on AV-2.
- \*Dimensional weight applies when shipped as a parcel package (via FedEx or UPS Ground).

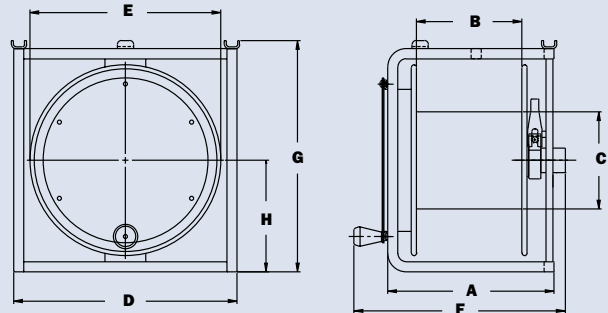

AV-1 and AV-2

# Series AVD

**With slotted divider discs.**

The primary advantage of a Series AVD is the addition of a slotted divider disc within the reel spool. This feature provides a convenient way for a user to have unobstructed access to both cable connector ends. Making it easy to pull off any length of cable and still have access to both connectors. There is no need to pull the entire length of cable off the reel before use.

- Communication, broadcast, and pro-audio applications.
- Rugged steel frame and aluminum spool construction.
- Black, non-reflective matte finish.
- Equipped with two durable rubber twist ties for cable ends.
- Slotted divider disc provides 2" wide space for storage of short cable.
- Frame clips allow stacking of reels.
- Adjustable cam-lock drag brake.
- Optional heavy-duty, locking caster wheels available.
- Pull handle available for AVD-2 and AVD-3 (Part No. 9949.0500).
- AVD-3 only — side-mounted punchable connector panels are standard.



**AVD-1**  
With caster mounting plates

**AVD-2**  
With optional casters and pull handle



**AVD-3**  
With optional casters



**AVD Series includes two durable rubber twist ties for cable ends.**  
Part No. 9949.0082

**PARTS DRAWING – AVD-1-ISO 222, AVD-2-ISO 223, AVD-3-ISO 224**

Model Number	Cable Capacity of Reel feet m										Approx. Weight without cable lb. kg			Reel Dimensions in. mm							
	O.D. (in) O.D. (mm)	.25 6	.32 8	.38 10	.41 10	.45 11	.49 12	.58 15	.67 17	NET	UPS/ FedEx SHIP Wt.	Freight SHIP Wt.	A	B	B1	C	D	E	F	G	H
<b>AVD-1</b>	<b>500</b>	<b>325</b>	<b>200</b>	<b>175</b>	<b>125</b>	<b>100</b>	-	-	<b>15</b>	<b>58*</b>	<b>22</b>	<b>10.25</b>	<b>6</b>	<b>2</b>	<b>6</b>	<b>13.75</b>	<b>11.75</b>	<b>13.25</b>	<b>14.25</b>	<b>7</b>	
	152	99	61	53	38	30	-	-	7	26	10	260	152	51	152	349	298	337	362	178	
<b>AVD-2</b>	-	-	-	<b>600</b>	<b>500</b>	<b>425</b>	<b>250</b>	<b>200</b>	<b>22</b>	<b>80*</b>	<b>31</b>	<b>13.13</b>	<b>7.5</b>	<b>2</b>	<b>8</b>	<b>20</b>	<b>18</b>	<b>13.25</b>	<b>20.5</b>	<b>10</b>	
	-	-	-	183	152	130	76	61	10	36	14	334	191	51	203	508	457	337	521	245	
<b>AVD-3</b>	-	<b>700</b>	<b>500</b>	<b>400</b>	<b>350</b>	<b>300</b>	<b>175</b>	-	<b>17</b>	<b>58*</b>	<b>23</b>	<b>12.82</b>	<b>7</b>	<b>2</b>	<b>6</b>	<b>16</b>	<b>15</b>	<b>13.25</b>	<b>16.88</b>	<b>7.88</b>	
	-	213	152	122	107	91	53	-	8	26	10	326	178	51	152	406	381	337	429	200	

**Notes:**

1. Specifications subject to change.
2. **Be sure to check dimensions and weights prior to ordering.**
3. Casters will add 2-3/4" to "G" dimension on AVD-1 and AVD-3. Casters will add 3-1/2" to "G" dimension on AVD-2.

\*Dimensional weight applies when shipped as a parcel package (via FedEx or UPS Ground).

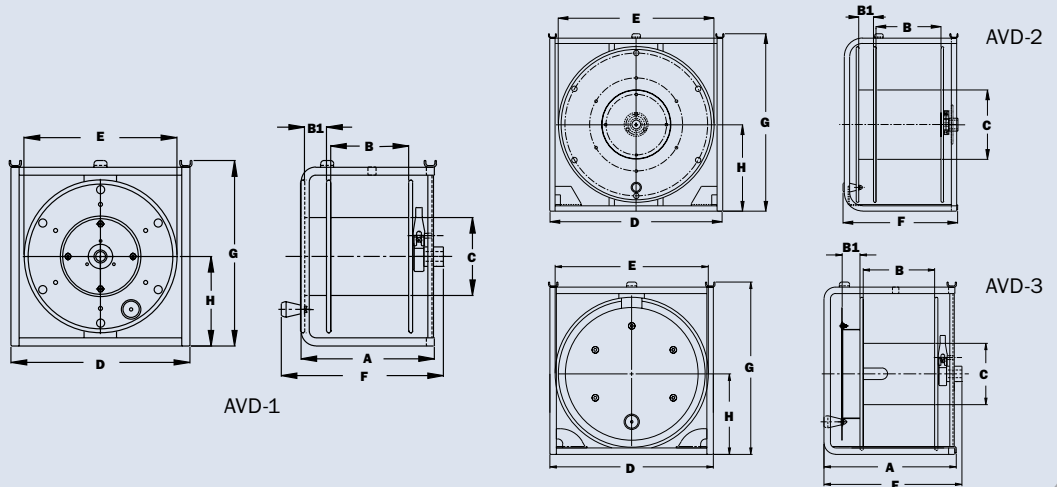

# Series AVC

**Handheld and lightweight.**

- Non-reflective black matte finish is standard.
- Optional storage drum extension.
- Equipped with one durable rubber twist tie for cable ends. "DE" models equipped with two ties.
- Adjustable cam-lock drag brake.

**AVC16-10-11**

- Crank handle permanently attached to the disc.

**AVC16-14-16 and AVC 20-14-16**

- Direct crank rewind.
- Optional pin lock available.



**AVC16-10-11**  
Standard configuration shown



**AVC16-10-11-DE**  
With optional drum extension



A new frame style is now standard on AVC Series reels. With this flexible modular design, the carry handle and the frame legs can be easily replaced in the event of damage. It is also possible to upgrade the carry handle to an optional ergonomic handle.



**AVC16-14-16-DE**  
With optional drum extension and ergonomic handle



**AVC20-14-16-DE**  
With optional drum extension



**AVC Series includes one durable rubber twist tie for cable ends. "DE" models equipped with two.**

Part No. 9949.0082

# Series AVC

**PARTS DRAWING – AVC16-10-11-ISO 88, AVC16-14-16/AVC20-14-16-ISO 121**

Model Number	Cable Capacity of Reel feet m									Approx. Weight without cable lb. kg			Reel Dimensions in. mm							
	O.D. (in) O.D. (mm)	.25 6	.32 8	.38 10	.41 10	.45 11	.49 12	.58 15	.67 17	NET	UPS/ FedEx. SHIP Wt.	Freight SHIP Wt.	A	B	C	D	E	F	G	H
AVC16-10-11	600	350	225	200	150	125	-	-	10	20*	12	11.5	7.5	4	11.5	10.75	12.75	14.75	6.88	
	183	107	69	61	46	38	-	-	5	9	6	292	191	102	292	273	324	375	175	
AVC16-14-16	1100	600	450	350	275	250	125	100	17	46*	21	11	7.5	6	15.5	14	12.75	19.25	8.62	
	335	183	137	107	84	76	58	30	8	21	10	279	191	152	394	356	324	489	219	
AVC20-14-16	1700	950	725	600	450	425	250	175	18	58*	23	15.5	12	6	15.5	14	16.75	19.25	8.62	
	518	290	221	183	137	130	76	53	8	26	10	394	305	152	394	356	425	489	219	
AVC16-10-11-DE	600	350	225	200	150	125	-	-	10	20*	12	11.5	7.5	4	11.5	10.75	14.25	14.75	6.88	
	183	107	69	61	46	38	-	-	5	9	6	292	191	102	292	273	362	375	175	
AVC16-14-16-DE	1100	600	450	350	275	250	125	100	17	46*	21	11	7.5	6	15.5	14	14.25	19.25	8.62	
	335	183	137	107	84	76	58	30	8	21	10	279	191	152	394	356	362	489	219	
AVC20-14-16-DE	1700	950	725	600	450	425	250	175	18	58*	23	15.5	12	6	15.5	14	18.75	19.25	8.62	
	518	290	221	183	137	130	76	53	8	26	10	394	305	152	394	356	476	489	219	

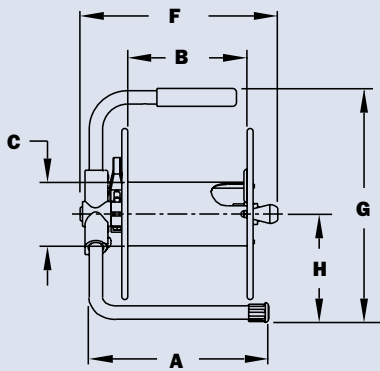

AVC16-10-11

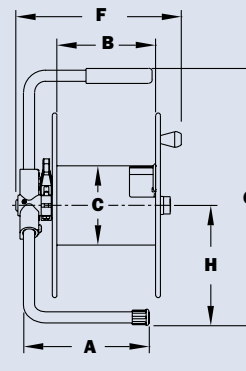
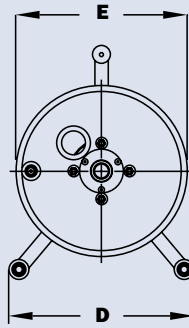

AVC16-14-16/AVC20-14-16

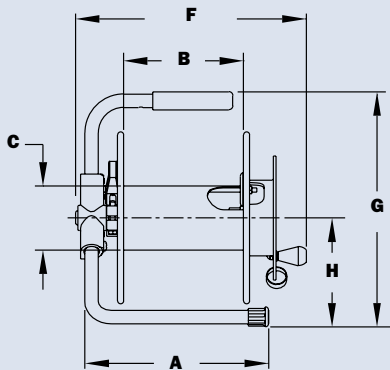
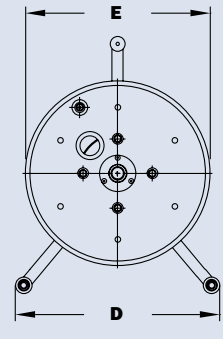

AVC16-10-11-DE

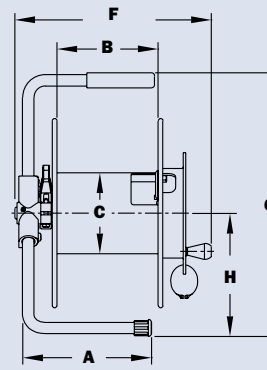
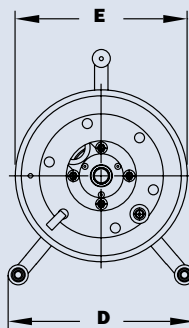

AVC16-14-16-DE/AVC20-14-16-DE

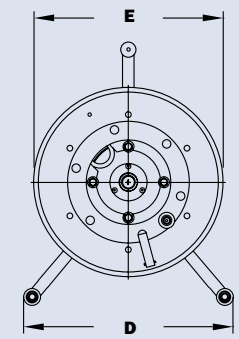

**Notes:**

1. Specifications subject to change.
  2. **Be sure to check dimensions and weights prior to ordering.**
- \*Dimensional weight applies when shipped as a parcel package (via FedEx or UPS Ground).

# Series AVC1500

**For longer lengths of cable.**

**AVC1500 Series**

- Standard direct crank. Permanently attached.
- Manual rewind models, spring actuated pin lock, cam-lock drag brake.
- Equipped with one durable rubber twist tie for cable ends. Divider disc models equipped with additional tie.
- Non-reflective black matte finish is standard.

**Options:**

- Heavy duty locking caster wheel set, includes 2 locking and 2 non-locking casters with mounting plates (Part No. 9949.0075).
- Frame-mounted carrying handles (Part No. 9955.0023).
- Divider discs, available with a cut-out.

**Note:** This disc location must be specified.



**AVC1500**  
Standard configuration shown



**AVC1520-17-18**

- Options shown:
- Slotted divider disc
  - Heavy-duty casters
  - Carrying handles
  - Caster extension brackets (see Note 3)



**AVC 1500 Series includes one durable rubber twist tie for cable ends. Divider disc models with two.**  
Part No. 9949.0082

**PARTS DRAWING – ISO 218**

Model Number See Note 3	Cable Capacity of Reel feet m									Approx. Weight without cable lb. kg			Reel Dimensions in. mm			
	O.D. (in) O.D. (mm)	.25 6	.32 8	.38 10	.41 10	.45 11	.49 12	.58 15	.67 17	NET	UPS/ FedEx. SHIP Wt.	Freight SHIP Wt.	A	B	F	X
<b>AVC1514-17-18</b>		<b>1250</b>	<b>700</b>	<b>550</b>	<b>400</b>	<b>325</b>	<b>300</b>	<b>200</b>	<b>125</b>	<b>23</b>	<b>68*</b>	<b>35</b>	<b>11</b>	<b>6</b>	<b>18.25</b>	<b>9.5</b>
		381	213	168	122	99	91	61	38	10	31	16	279	152	464	241
<b>AVC1516-17-18</b>		<b>1700</b>	<b>1000</b>	<b>700</b>	<b>600</b>	<b>500</b>	<b>400</b>	<b>300</b>	<b>200</b>	<b>24</b>	<b>68*</b>	<b>36</b>	<b>13</b>	<b>8</b>	<b>20.25</b>	<b>11.5</b>
		518	305	213	183	152	122	91	61	11	31	16	330	203	514	292
<b>AVC1520-17-18</b>		<b>2500</b>	<b>1450</b>	<b>1100</b>	<b>950</b>	<b>775</b>	<b>625</b>	<b>475</b>	<b>300</b>	<b>25</b>	<b>80*</b>	<b>40</b>	<b>17</b>	<b>12</b>	<b>24.25</b>	<b>15.5</b>
		769	442	335	290	236	191	145	91	11	36	18	432	305	616	394
<b>AVC1522-17-18</b>		<b>3000</b>	<b>1700</b>	<b>1250</b>	<b>1050</b>	<b>875</b>	<b>700</b>	<b>525</b>	<b>350</b>	<b>26</b>	<b>98*</b>	<b>46</b>	<b>19</b>	<b>14</b>	<b>26.25</b>	<b>17.5</b>
		914	518	381	320	267	213	160	107	12	44	21	403	356	667	445

**Notes:**

1. Specifications subject to change.
  2. **Be sure to check dimensions and weights prior to ordering.**
  3. For AVC 1520-17-18 and AVC 1522-17-18 with caster extension brackets, dimension D=20," dimension G=22."
- \*Dimensional weight applies when shipped as a parcel package (via FedEx or UPS Ground).

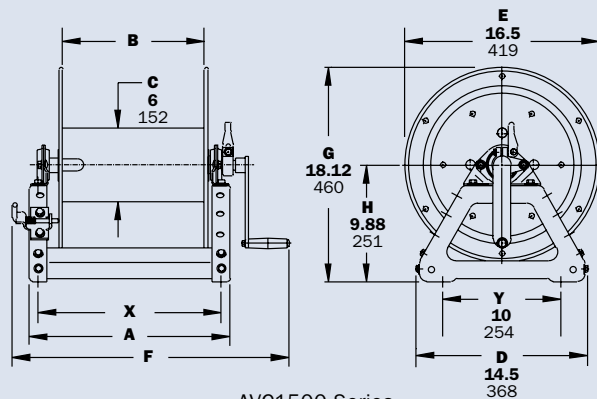

AVC1500 Series



# Model AVX-100

**For stage box units.**

- Rugged steel and aluminum construction.
- Non-reflective black matte finish is standard.
- Equipped with one durable rubber twist tie for cable ends.
- Durable tray provided for storage of stage box units.
- Slotted divider disc design allows connector pigtails to be safely stored alongside snake cable.
- Ergonomic carrying handle.
- Adjustable cam-lock drag brake.



**AVX-100**  
Standard configuration shown

**AVX-100**  
Standard configuration shown (cable not supplied with reel)



**AVX Series includes one durable rubber twist tie for cable ends.**  
Part No. 9949.0082

**PARTS DRAWING – ISO 199**

Model Number	Cable Capacity of Reel feet m								Approx. Weight without cable lb. kg			Reel Dimensions in. mm							
	O.D. (in) O.D. (mm)	.25 6	.38 10	.41 10	.45 11	.49 12	.58 15	.67 17	NET	UPS/ FedEx. SHIP Wt.	Freight SHIP Wt.	A	B	B1	C	D	E	F	G
<b>AVX-100</b>	-	-	-	<b>275</b>	<b>225</b>	<b>150</b>	<b>100</b>	<b>16</b>	<b>58*</b>	<b>21</b>	<b>11</b>	<b>6</b>	<b>3</b>	<b>6</b>	<b>12</b>	<b>14</b>	<b>13.5</b>	<b>21</b>	<b>11.25</b>
	-	-	-	84	69	46	30	7	26	10	279	152	76	152	305	356	343	533	286

**Notes:**

1. Specifications subject to change.
  2. **Be sure to check dimensions and weights prior to ordering.**
- \*Dimensional weight applies when shipped as a parcel package (via FedEx or UPS Ground).

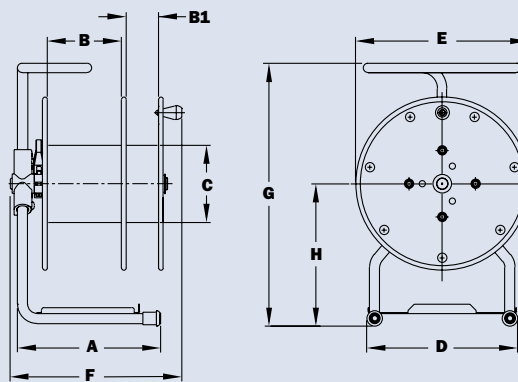

AVX-100

# Series AVC1150/AVATC1250

**Reels on wheels and compact storage.**

These direct crank rewind reels are equipped with one-piece foot, and removable steel handlebar for long-term storage and shipping.

- Cam-lock brake is standard.
- Non-reflective black matte finish is standard.
- Equipped with one durable rubber twist tie for cable ends. Divider disc models equipped with additional tie.
- For compact storage, optional folding handle or removable crank handle are available.
- Optional divider discs are available.

**AVC1150**

- Hard rubber tires and a 7/8" x 1-3/4" (22.2 mm x 44.4 mm) opening in the drum.
- Optional pneumatic tires available. See Note 3.

**AVATC1250**

- Pneumatic tires and a 4" x 5-1/2" (101.6 mm x 139.7 mm) drum opening.
- Large capacity spool.



**AVC1150**  
Shown with optional folding handle

**AVATC1250**  
Standard configuration shown



**AVC 1150/1250 Series includes one durable rubber twist tie for cable ends. Divider disc models with two.**  
Part No. 9949.0082

**PARTS DRAWING – AVC 1150–ISO 48, AVATC 1250–ISO 87**

Model Number	Cable Capacity of Reel feet m								Approx. Weight without cable lb. kg			Reel Dimensions in. mm							
	O.D. (in) O.D. (mm)	.25 6	.38 10	.41 10	.45 11	.49 12	.58 15	.67 17	NET	UPS/ FedEx. SHIP Wt.	Freight SHIP Wt.	A	B	C	D	E	F	G	H
<b>AVC1150</b>	-	<b>950</b>	<b>800</b>	<b>700</b>	<b>575</b>	<b>425</b>	<b>250</b>	<b>44</b>	<b>100*</b>	<b>79</b>	<b>21.5</b>	<b>12</b>	<b>6</b>	<b>21</b>	<b>16.5</b>	<b>25</b>	<b>39</b>	<b>13.81</b>	
	-	290	244	213	175	130	76	20	45	36	546	305	152	533	419	635	991	351	
<b>AVATC1250</b>	-	<b>1800</b>	<b>1500</b>	<b>1200</b>	<b>1000</b>	<b>800</b>	<b>500</b>	<b>82</b>	<b>147*</b>	<b>117</b>	<b>24.88</b>	<b>11.5</b>	<b>8</b>	<b>23.31</b>	<b>23</b>	<b>27.25</b>	<b>40</b>	<b>17.25</b>	
	-	549	457	366	305	244	152	37	67	53	632	292	203	592	584	692	1016	438	

**Notes:**

1. Specifications subject to change.
2. Be sure to specify model number, O.D., length and weight of cable, etc.
3. Optional AT wheels on AVC1150 increase dimensions. Add 3-1/4" to dimension "A," add 5" to dimension "F."
4. **Be sure to check dimensions and weights prior to ordering.**

\* Dimensional weight applies when shipped as a parcel package (via FedEx or UPS Ground). Some assembly required.

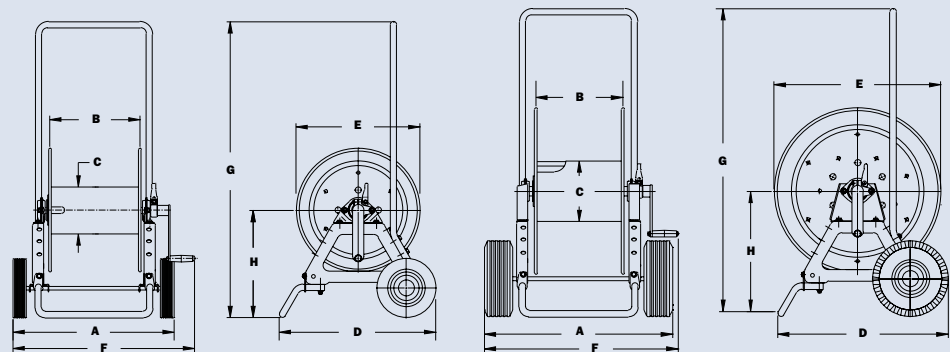

AVC1150

AVATC1250

# Series AVCQ20-14-16

**For small vehicles and storage areas.**

Sturdy steel construction with direct crank rewind provides fast, easy pick-up. Perfect for applications with long cable runs or large diameter cable.

- Use multiple spools on one frame.
- Quick release spool removal.
- Self-storing removable rewind crank.
- Non-reflective black matte finish is standard.
- Adjustable friction brake is standard.



**AVCQ20-14-16**



**AVCQ Frame** – includes crank handle  
(Part No. 9906.0910)



**AVCQ Spool**

Model Number	Cable Capacity of Reel feet m								Approx. Weight without cable lb. kg			Reel Dimensions in. mm							
	O.D. (in) O.D. (mm)	.25 6	.38 10	.41 10	.45 11	.49 12	.58 15	.67 17	NET	UPS/ FedEx. SHIP Wt.	Freight SHIP Wt.	A	B	C	D	E	F	G	H
<b>AVCQ20-14-16</b>	–	<b>700</b>	<b>525</b>	<b>400</b>	<b>400</b>	<b>250</b>	<b>175</b>	<b>18</b>	<b>58*</b>	<b>45</b>	<b>15</b>	<b>12</b>	<b>6</b>	<b>15.5</b>	<b>14</b>	<b>17.50</b>	<b>19</b>	<b>8.62</b>	
	–	213	160	122	122	76	53	8	26	20	381	305	152	394	356	445	483	219	

**Notes:**

1. Specifications subject to change.
2. Extra spools can be stored on vertical or horizontal spindles of your own design. When needed, transfer spool to frame for transport to work site.
3. **Be sure to check dimensions and weights prior to ordering.**

\* Dimensional weight applies when shipped as a parcel package (via FedEx or UPS Ground). Some assembly required.

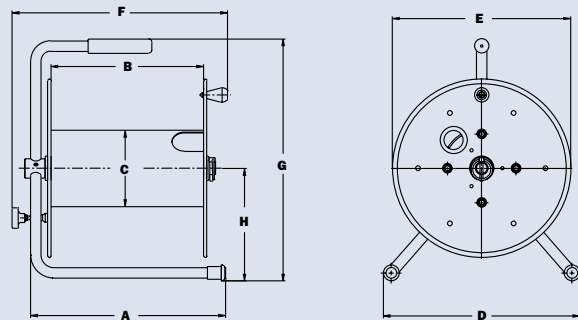

AVCQ20-14-16



# You Can't Buy A Better Reel.

Here's what makes Hannay Reels the industry choice:



- **Deployment and pickup** – Direct rewind allows for easy setup and tear down
- **Storage** – Stackable for efficient storage and transport
- **Portability** – Ergonomic handle design makes moving and carrying easier and more comfortable
- **Made exclusively for your industry** – Cable reels are designed and built specifically for your business – never retrofitted to the job – so you can expect unsurpassed fit and function



## Find reels for every need



### Cable Reels

Find out more about:

- Manual and power rewind reels
- Storage reels
- Reels for live electric cable
- Portable reels
- Static and truck grounding reels



### Ordering & Accessory Guide

Learn more about:

- Selecting the right reel
- Reel components
- Available accessories
- How to spec and order reels and accessories
- Ordering options
- Hannay Reels policies

View all our reel catalogs online at [hannay.com](http://hannay.com)



Family owned and operated since 1933, Hannay Reels is the world leader in both OEM and aftermarket applications. Hannay offers thousands of standard hose reel and cable reel models, as well as unmatched custom capabilities. We can easily and affordably customize a reel to meet your exact specifications – built to last, delivered fast. Additional catalogs are available through your local Hannay Reels dealer or online at [hannay.com](http://hannay.com).



553 State Route 143 | Westerlo, New York 12193  
Email: [reels@hannay.com](mailto:reels@hannay.com) | [hannay.com](http://hannay.com)



All Hannay reels are constructed of quality heavy gauge steel (optional aluminum or stainless steel also available on most models).

Phone: 518-797-3791  
Toll Free: 1-877-467-3357

Domestic FAX: 1-800-733-5464  
International FAX: 518-797-3259

Form H-0508-A/V REV 5 WEB 7-18

